

REV	DESCRIPTION	DATE
A	CORRECTED RACK MOUNT BRACKET DETAIL	10/11/01

NOISES

MATERIAL TOP & BOTTOM 0.062" STEEL, SIDES, FRONT, REAR & HORIZONTAL SUPPORTS 0.125" ALUMINUM, DIMENSIONS ARE TAKEN WITH THE PAINTED SURFACE

FINISH TOP, BOTTOM & SIDE PANELS, TEXTURED BLACK, FRONT/REAR PANELS ON SMOOTH BLACK, ONE CONTEMPRA GRAY (RAL 7032), ALL POWDER PAINT.

FRONT VIEW

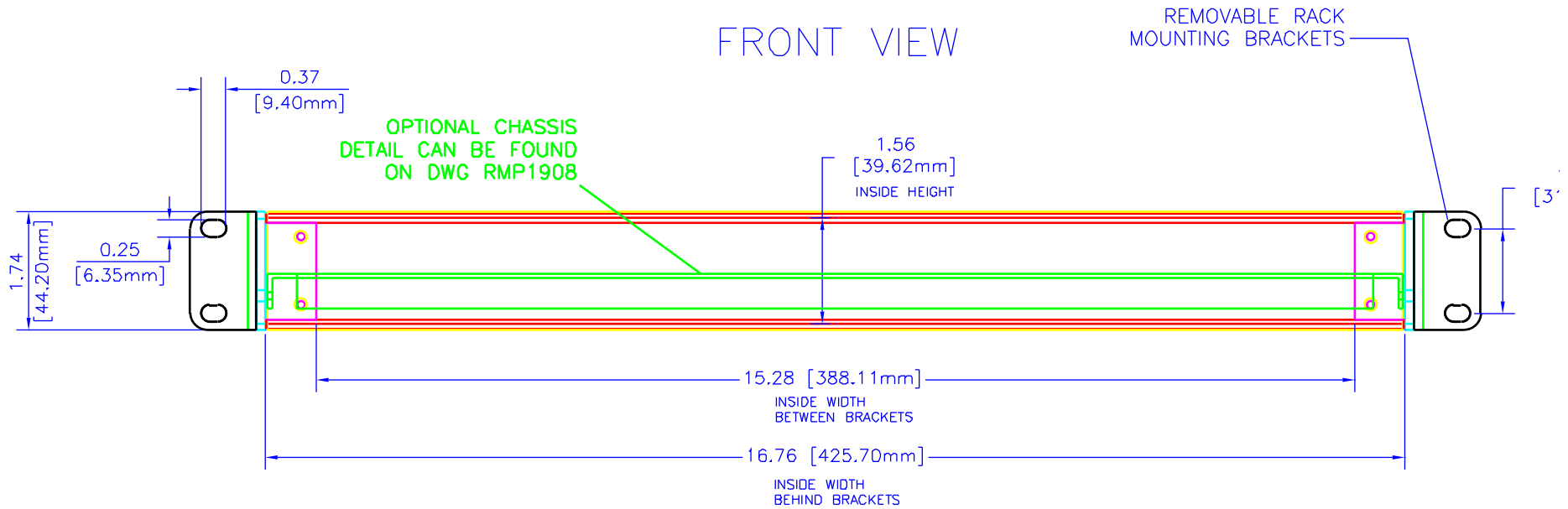

UNLESS OTHERWISE SPECIFIED DIMENSIONS ARE IN INCHES	
X	+/- .1
XX	+/- .02
XXX	+/- .015
PLPS	+/- .008
ANGLES	+/- .5 DEG.



**HAMMOND
MANUFACTURING**

HAMMOND ENCLOSURES PROPRIETARY RIGHTS TO THE MATERIALS ON THIS DRAWING ARE RESERVED AND ARE NOT TO BE USED AS A REFERENCE FOR REPLICATING INFORMATION UNLESS THE INFORMATION HAS BEEN WRITTEN PERMISSION FROM HAMMOND MANUFACTURING.

TITLE	
HAMMOND RMCV SERIES RACK ENCLOSURE	
DRAWN BY	MJM
DATE	10/04/01
SCALE	PAGE 1 OF 3
PART NUMBER	
RMCV19018	

SIDE VIEW

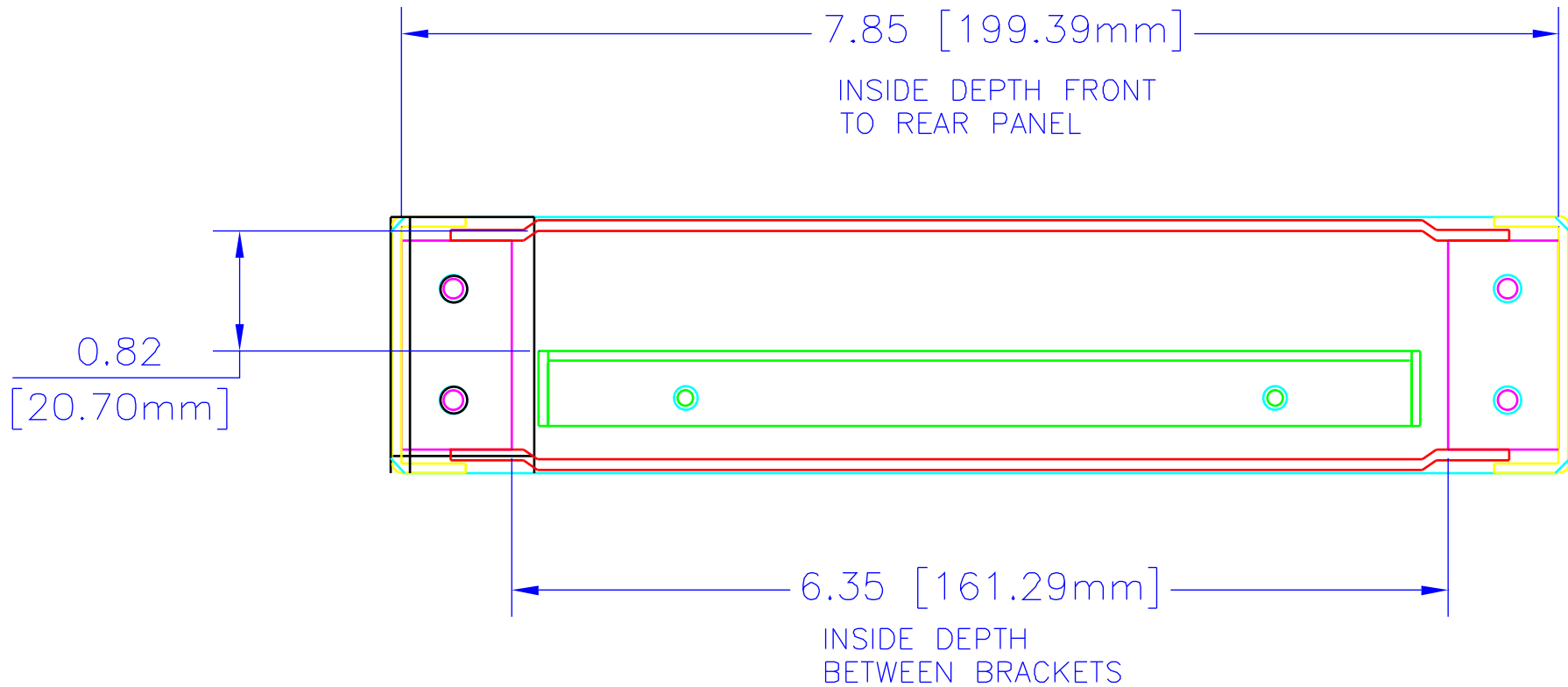

UNLESS OTHERWISE SPECIFIED
DIMENSIONS ARE IN INCHES

x	+/- .1
xx	+/- .02
xxx	+/- .015
xxxx	+/- .008
ANGLES	+/- 5 DEG.

NOTICE:
HAMMOND MANUFACTURING RESERVES THE RIGHT TO CHANGE THE MATERIAL OR THIS DRAWING IF IT IS DETERMINED TO BE USED AS A REFERENCE FOR ENGINEERING INFORMATION ONLY. THIS INFORMATION MAY NOT BE USED TO MANUFACTURE PRODUCTS WITHOUT WRITTEN PERMISSION FROM HAMMOND MANUFACTURING.



**HAMMOND
MANUFACTURING**

WEB: WWW.HAMMONDMFG.COM

TITLE		HAMMOND RMCV SERIES RACK ENCLOSURE	
DRAWN BY	MJM	DATE	10/04/01
SCALE		PAGE	2 OF 3
PART NUMBER	RMCV19018		

TOP VIEW

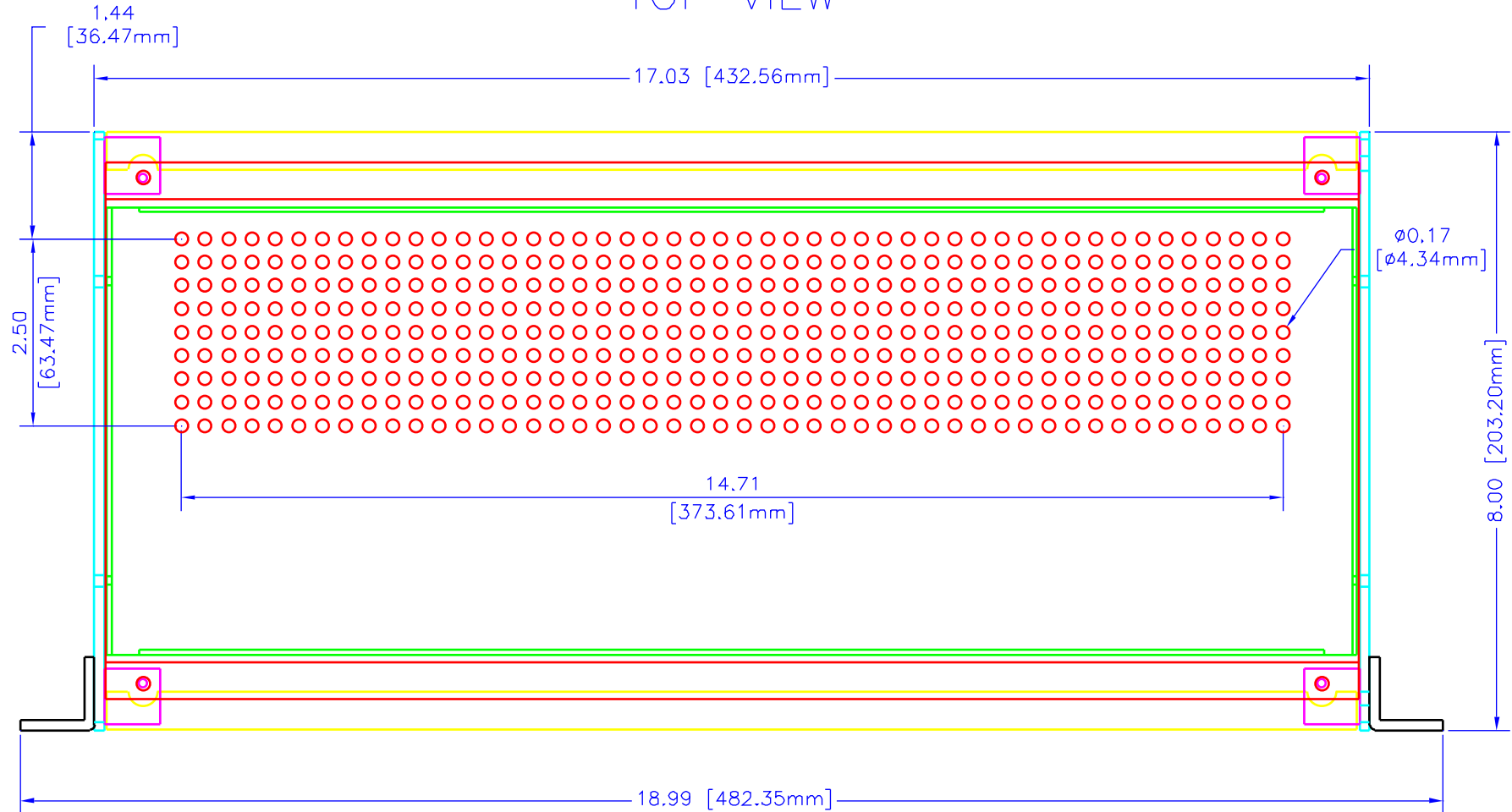

UNLESS OTHERWISE SPECIFIED DIMENSIONS ARE IN INCHES.	
X	+/- .1
XX	+/- .02
XXX	+/- .015
DITS	+/- .008
ANGLES	+/- 5 DEG.
NOTICE	
HAMMOND'S LOGO, PROPRIETARY RIGHTS TO THE MARK OF THIS DRAWING IS INTENDED TO BE USED AS A REFERENCE FOR ENGINEERING INFORMATION ONLY. THIS INFORMATION MAY NOT BE USED TO MANUFACTURE PRODUCTS WITHOUT WRITTEN PERMISSION FROM HAMMOND MANUFACTURING.	

**HAMMOND
MANUFACTURING**
 WEB: WWW.HAMMONDMFG.COM

TITLE		HAMMOND RMCV SERIES RACK ENCLOSURE	
DRAWN BY	MJM	DATE	10/04/01
SCALE		PAGE	3 OF 3
PART NUMBER		RMCV19018	