

DATE	REV.	DESCRIPTION	DR	CK	REL

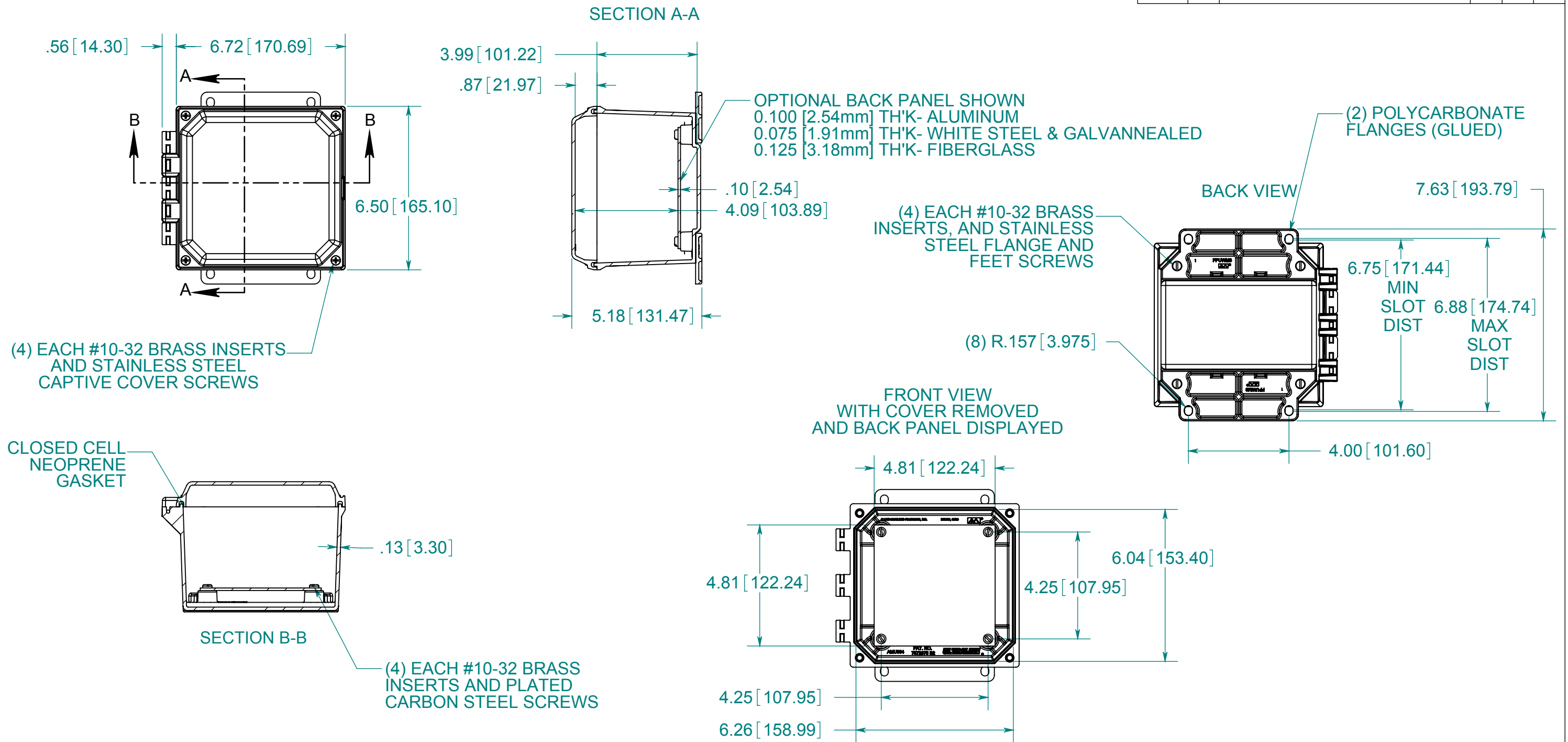

**MATERIAL:**  
 BOX- COMPRESSION MOLDED FIBERGLASS REINFORCED POLYESTER  
 COVER- COMPRESSION MOLDED FIBERGLASS REINFORCED POLYESTER  
 CLEAR COVER AND WINDOWS- POLYCARBONATE

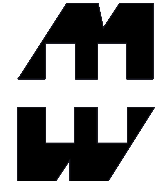

**PART No. PJU664CCF**  
 for more information visit  
[www.hammfg.com](http://www.hammfg.com)  
 Data subject to change without notice  
 Drawing Not to Scale