

DATE	REV.	DESCRIPTION	DR	CK	REL

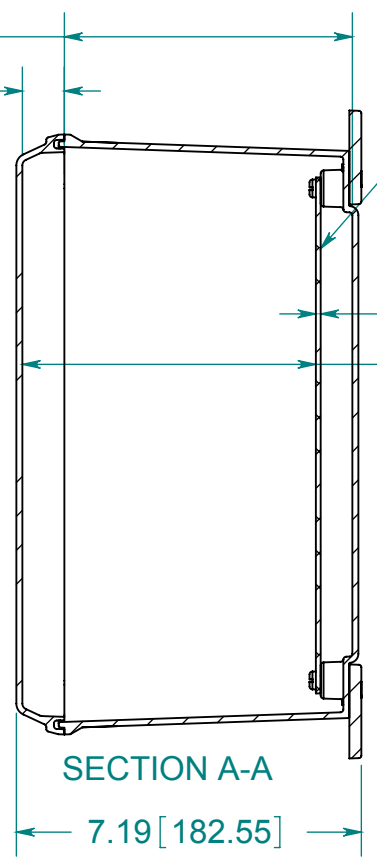

OPTIONAL BACK PANEL  
 0.100 [2.54] TH'K- ALUMINUM  
 0.075 [1.91] TH'K- WHITE STEEL & GALVANNEALED  
 0.125 [3.18] TH'K- FIBERGLASS

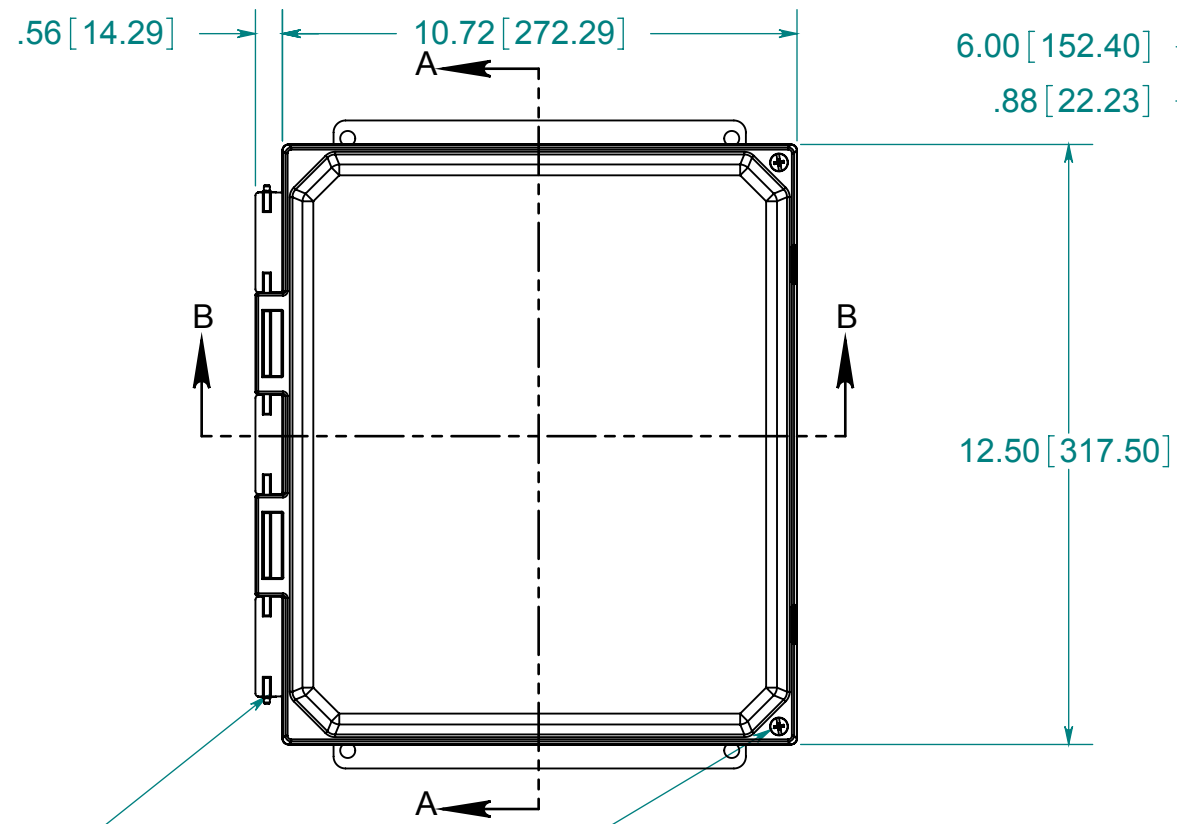
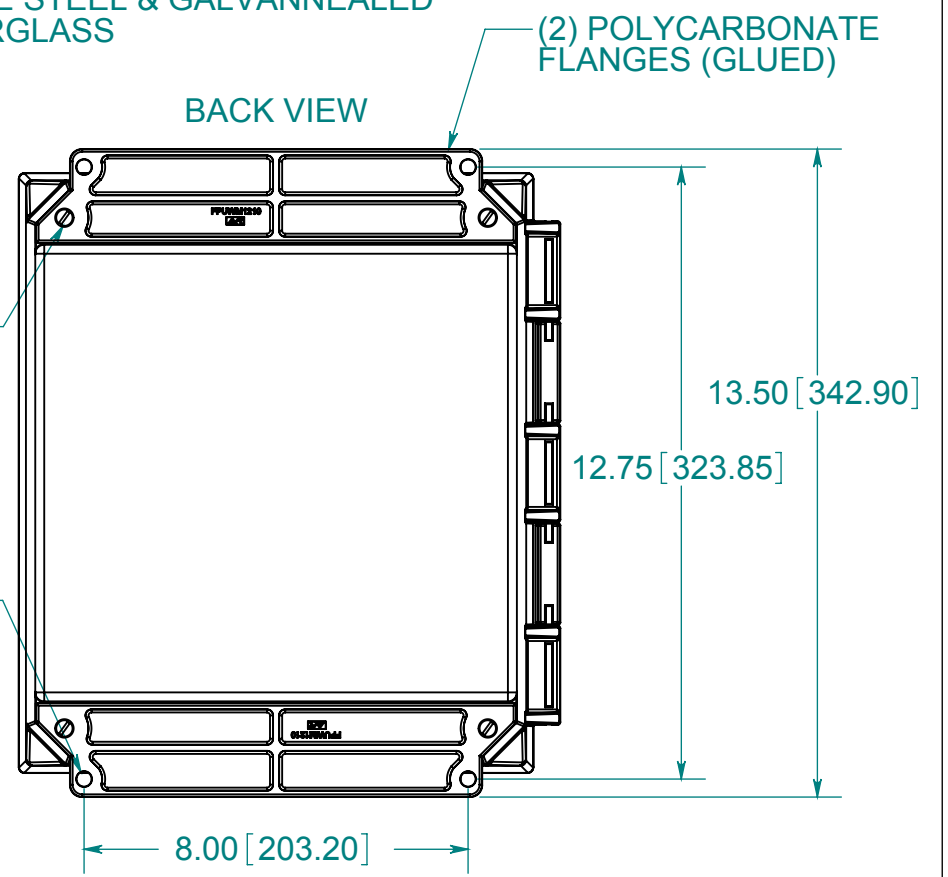

STAINLESS STEEL HINGE PIN AND (2) STAINLESS STEEL PUSH NUT FASTENERS  
 (2) EACH #10-32 BRASS INSERTS AND STAINLESS STEEL CAPTIVE COVER SCREWS WITH RETAINING O-RING

FRONT VIEW WITH COVER REMOVED AND BACK PANEL DISPLAYED

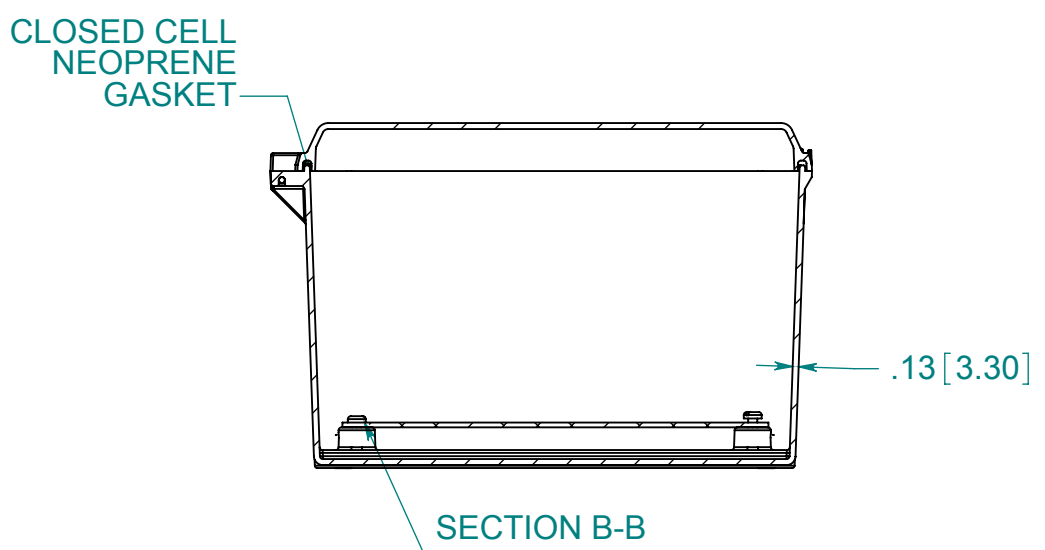
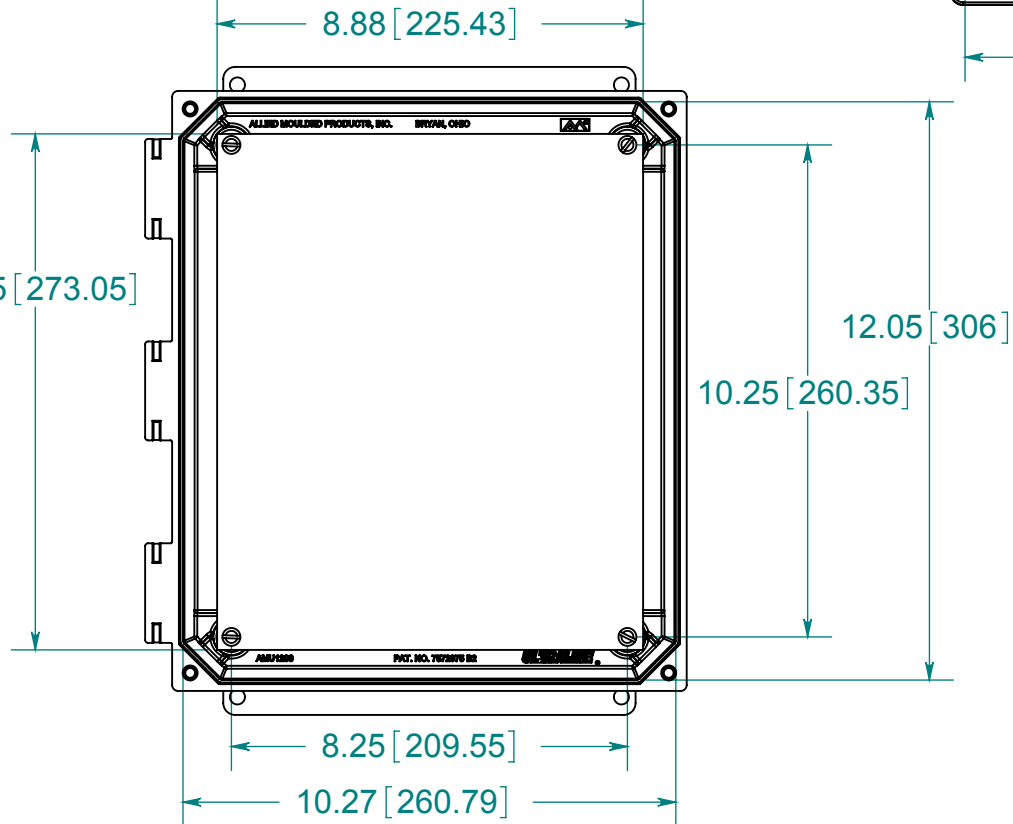

(4) EACH #10-32 BRASS INSERTS AND PLATED CARBON STEEL SCREWS

MATERIAL:  
 BOX-COMPRESSION MOLDED FIBERGLASS REINFORCED POLYESTER  
 COVER- COMPRESSION MOLDED FIBERGLASS REINGORCED POLYESTER  
 CLEAR COVER AND WINDOWS- POLYCARBONATE

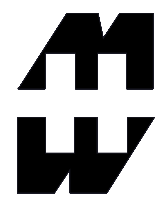

PART No. PJU1206CCHF  
 for more information visit [www.hammfg.com](http://www.hammfg.com)  
 Data subject to change without notice  
 Drawing Not to Scale