

DATE	SYM.	DESCRIPTION	DR	CK	REL

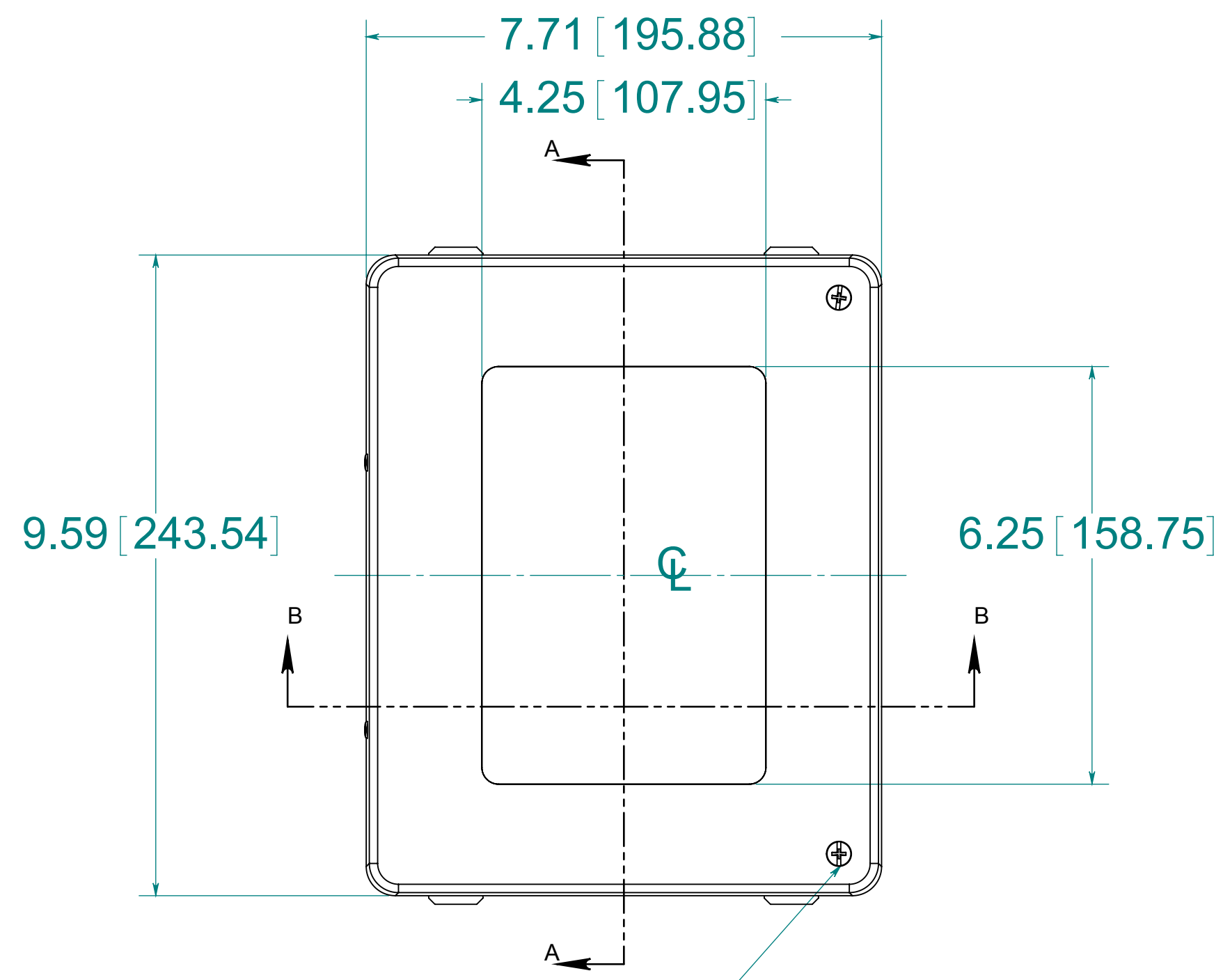

(2) EACH #10-32 BRASS INSERTS, AND STAINLESS STEEL CAPTIVE COVER SCREWS WITH RETAINING O-RING

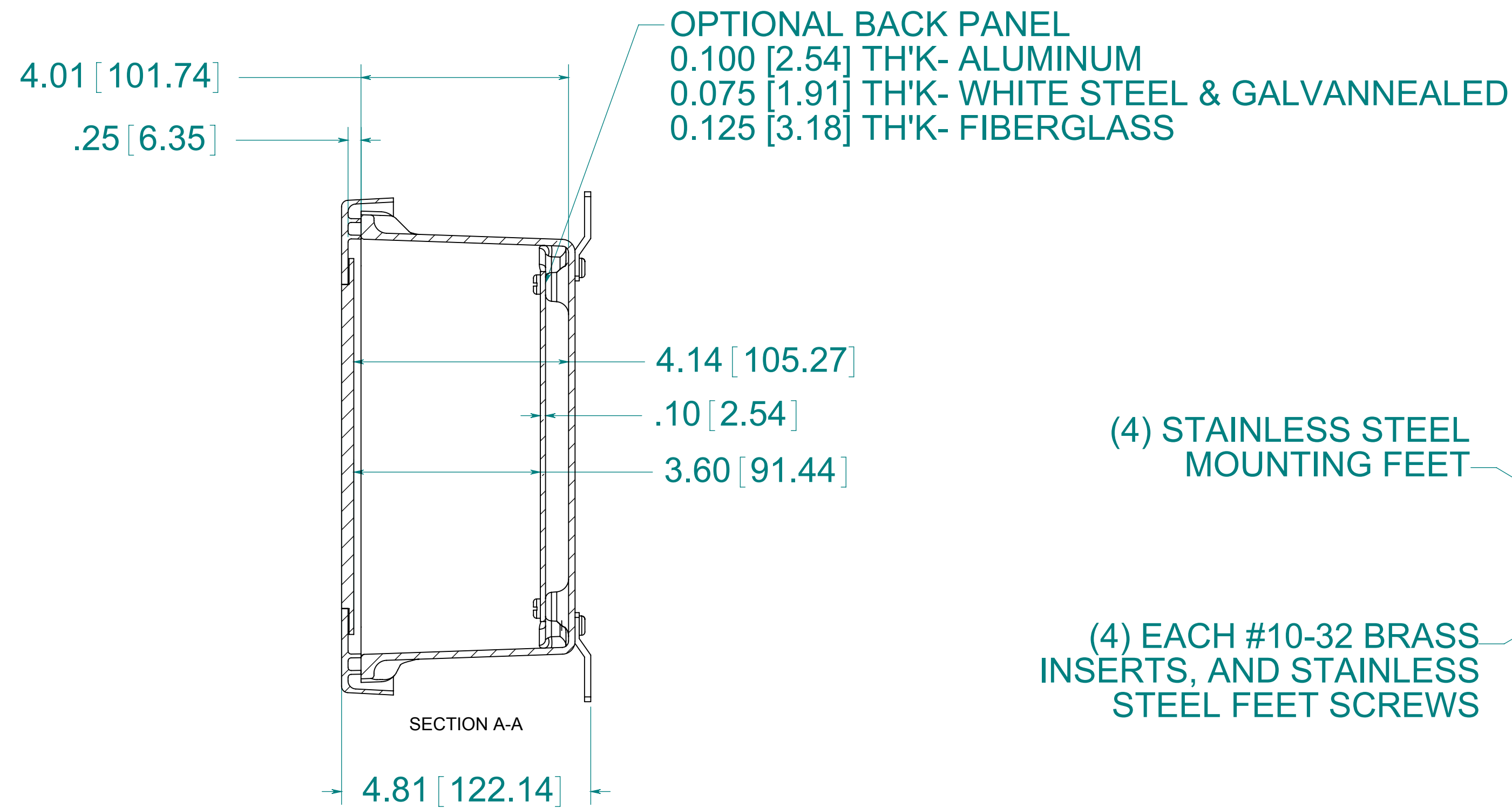

BACK VIEW
 (4) STAINLESS STEEL MOUNTING FEET

(4) EACH #10-32 BRASS INSERTS, AND STAINLESS STEEL FEET SCREWS

(4) Ø.34 [8.74]

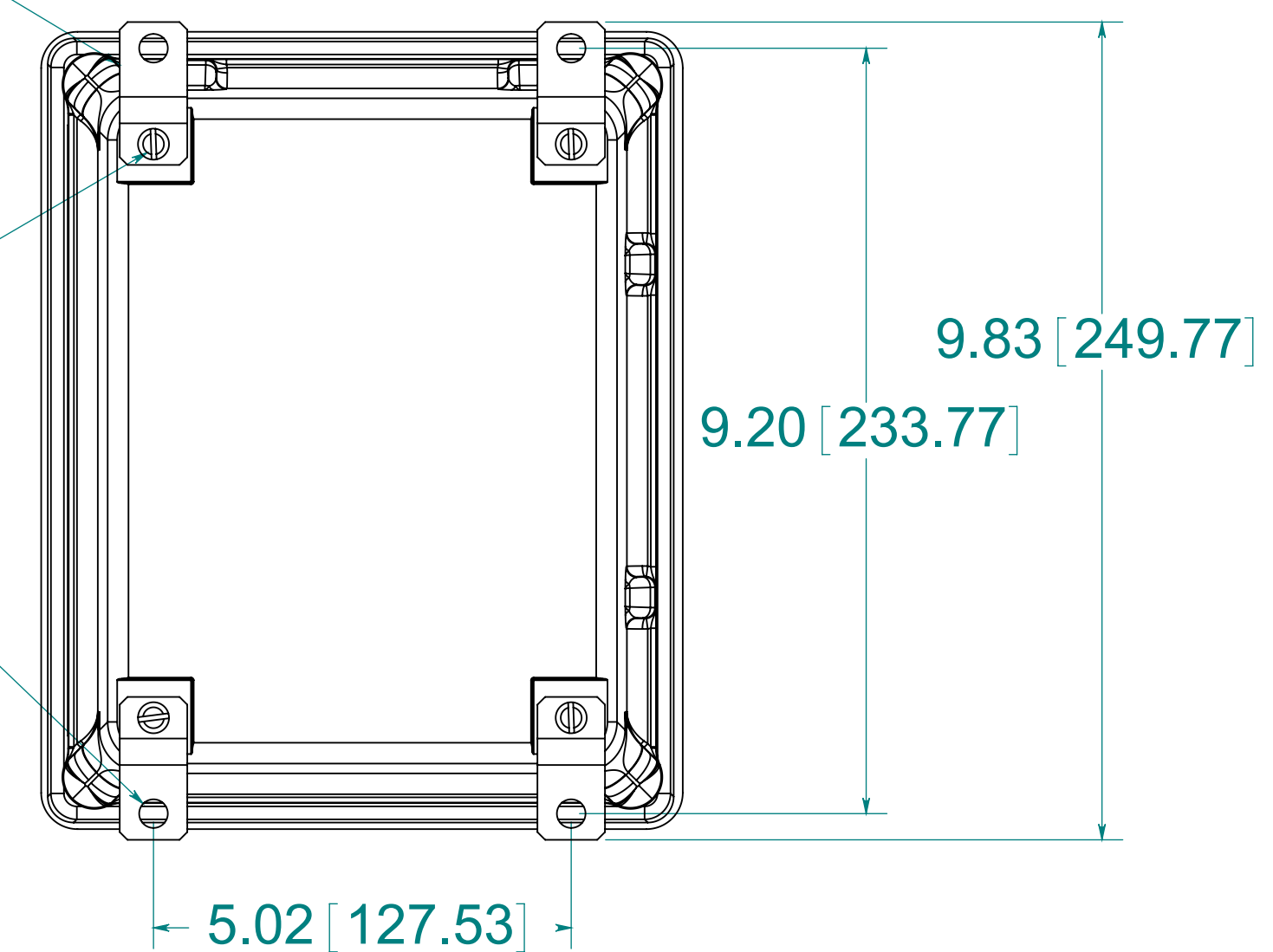

CLOSED CELL NEOPRENE GASKET

STAINLESS STEEL HINGE

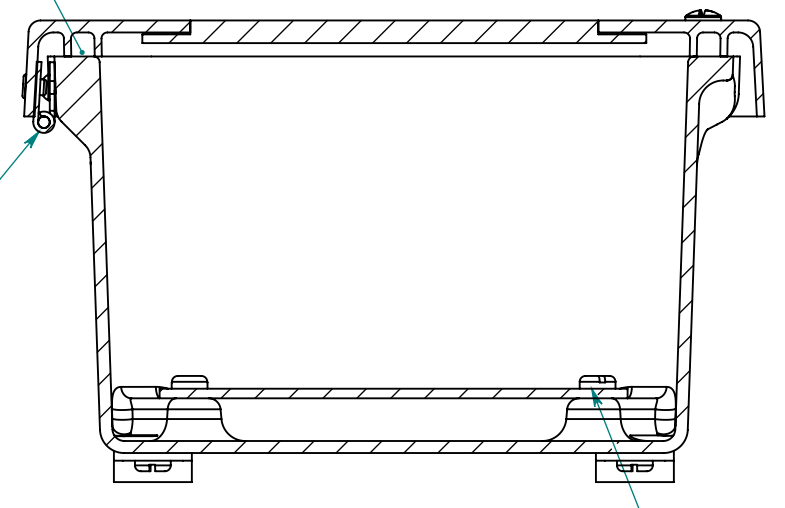

(4) EACH #10-32 BRASS INSERTS AND PLATED CARBON STEEL SCREWS

FRONT VIEW WITH COVER REMOVED AND BACK PANEL SHOWN

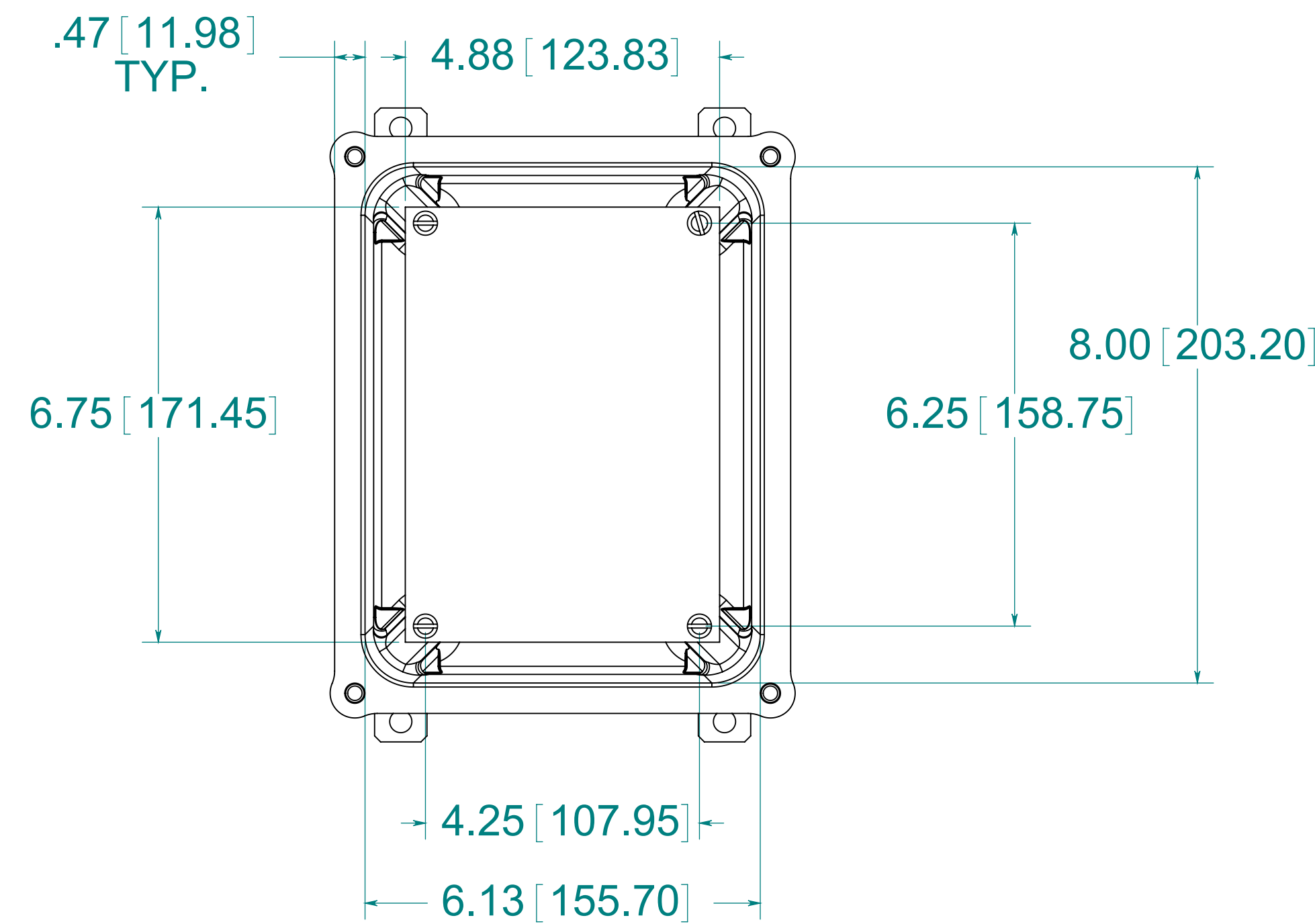

MATERIAL:
 BOX- COMPRESSION MOLDED FIBERGLASS REINFORCED POLYESTER
 COVER- COMPRESSION MOLDED FIBERGLASS REINFORCED POLYESTER
 WINDOW- POLYCARBONATE

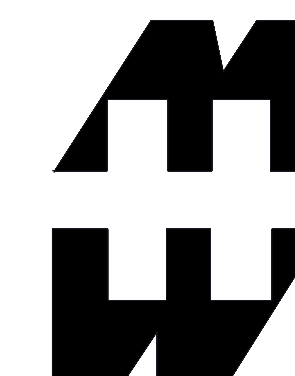

PART No. PJ864HW
 for more information visit www.hammfg.com
 Data subject to change without notice
 Drawing Not to Scale