

DATE	REV.	DESCRIPTION	DR	CK	REL

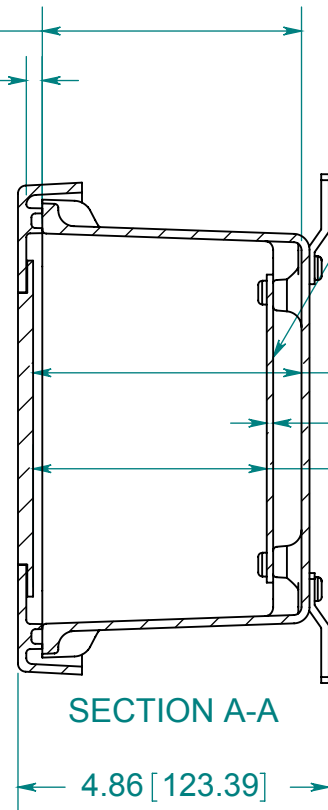

OPTIONAL BACK PANEL
 0.100 [2.54] TH'K- ALUMINUM
 0.075 [1.91] TH'K- WHITE STEEL & GALVANNEALED
 0.125 [3.18] TH'K- FIBERGLASS

(4) STAINLESS STEEL MOUNTING FEET
 .10 [2.54]
 3.65 [92.74]
 (4) EACH #10-32 BRASS INSERTS, AND STAINLESS STEEL FEET SCREWS

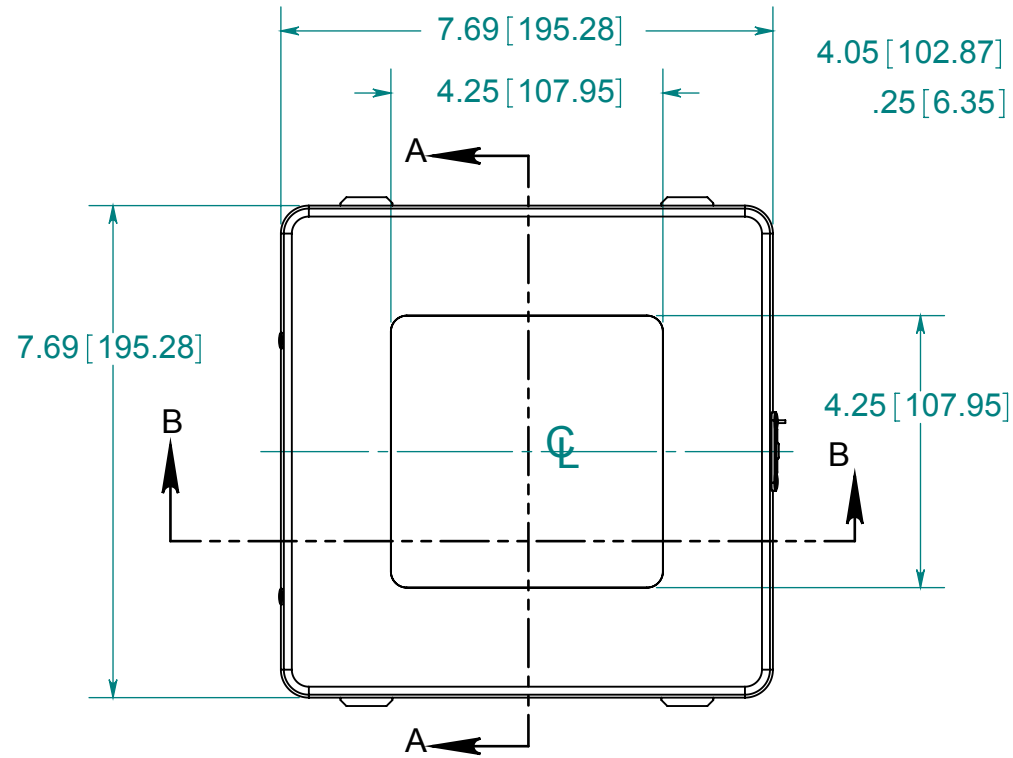
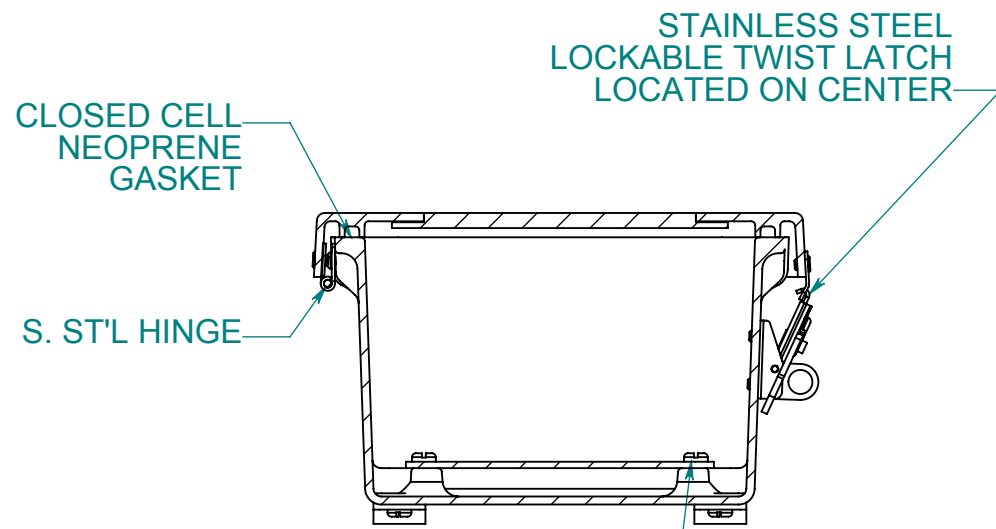
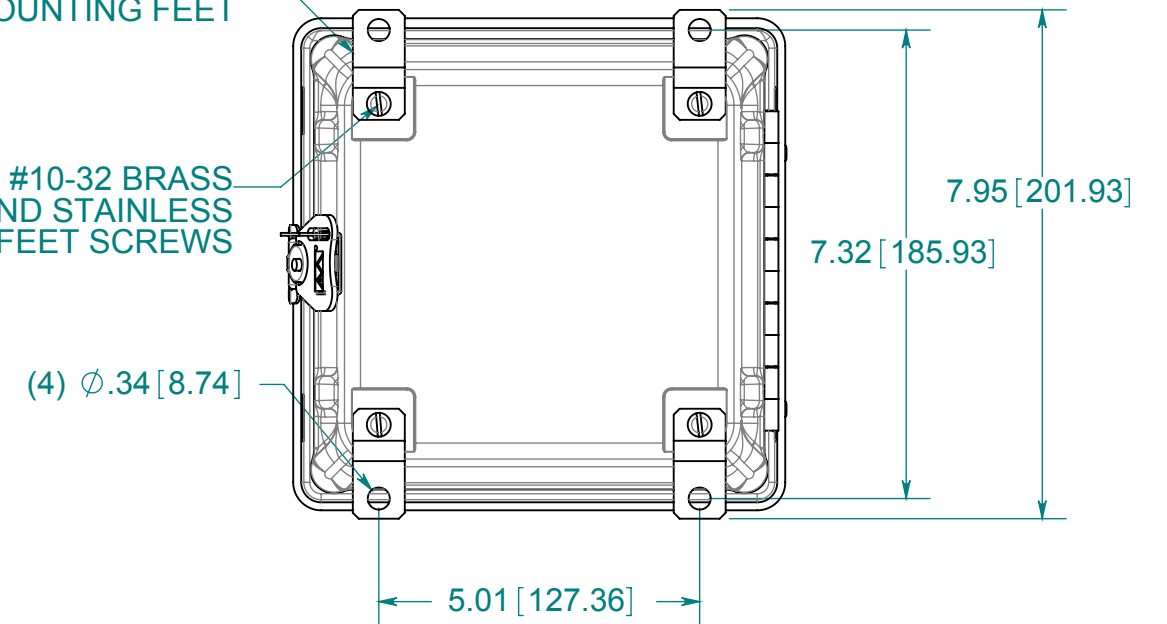

SECTION B-B
 (4) EACH #10-32 BRASS INSERTS AND PLATED CARBON STEEL SCREWS

FRONT VIEW WITH COVER REMOVED AND BACK PANEL SHOWN

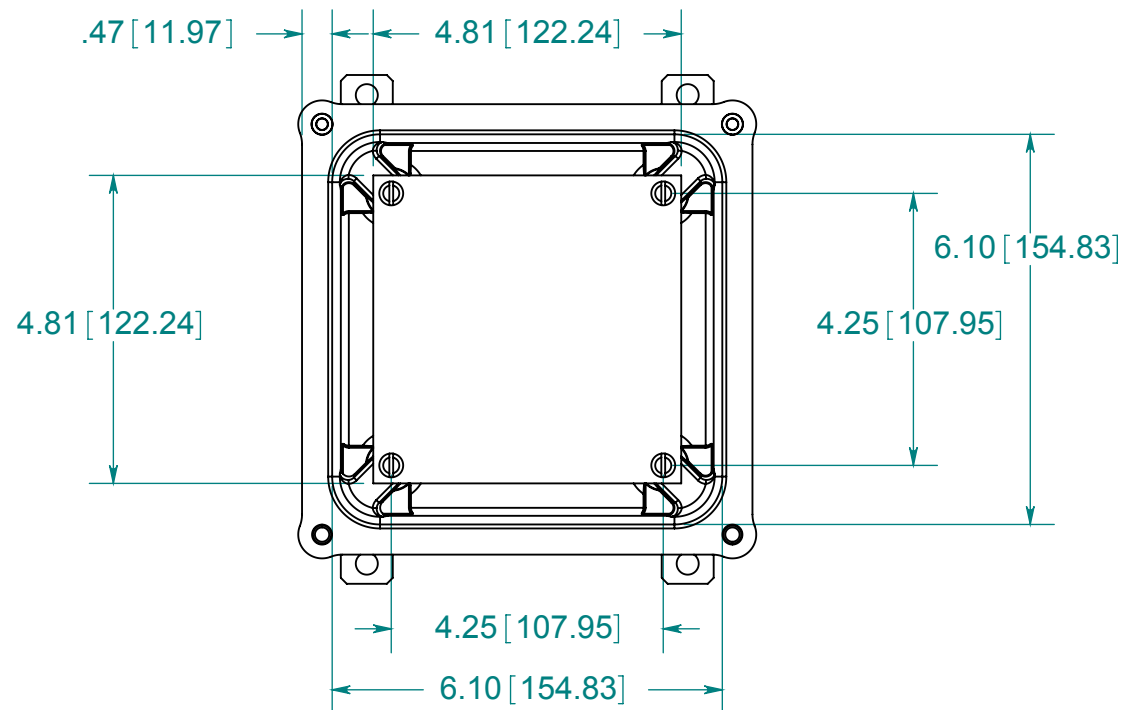

MATERIAL:
 BOX- COMPRESSION MOLDED FIBERGLASS REINFORCED POLYESTER
 COVER- COMPRESSION MOLDED FIBERGLASS REINFORCED POLYESTER
 WINDOW- POLYCARBONATE

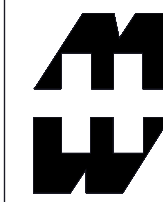

PART No. PJ664TW
 for more information visit www.hammfg.com
 Data subject to change without notice
 Drawing Not to Scale